

GATOR PUMPS

When you need to move large volumes of water or heavy solids and you want a pump that's built to last, you need a GATOR trailer mounted pump or vertical centrifugal pump! GATOR high volume pumps are used for flood irrigation, flood control, liquid waste pumping, pond transfer in wildlife management, fish hatcheries, oil well reserve pits, and a variety of other application.

GATOR Pumps are custom designed and fabricated in solid steel and can be powered by tractor, diesel, or hydraulic power sources. Pumps are available in several configurations, including trailer, vertical, and floating versions.

GATOR pumps are unique in that they are virtually maintenance-free due to a design without seals, check valves or priming devices. Many GATOR Pumps sold the first year the company began manufacturing are still in operation – since 1977!

Our customers include individuals and companies in the agriculture, aqua-culture and oilfield industries as well as hunting and fishing concerns, and municipalities. GATOR Pumps are used extensively by the U.S. Army Corps of Engineers, U.S. Fish & Wildlife Services, U.S. Coast Guard, and other federal, state and municipal government agencies.

When you need to move water or heavy suspended solids, get it moving now ... GET A GATOR !

PUMP PERFORMANCE					
PUMP MODEL	DISCHARGE IN (cm)	SUCTION	FLOW GPM (l/m)	HEAD FT (m)	POWER HP (kw)
540 RPM MODELS					
SUNFISH	4 (10)	DOUBLE	750 (2800)	46 (14)	20 (15)
MUSKRAT	6 (15)	DOUBLE	1300 (4900)	46 (14)	30 (22)
OTTER	8 (20)	DOUBLE	2000 (7600)	46 (14)	40 (30)
SEAL	10 (25)	DOUBLE	3000 (11400)	46 (14)	60 (45)
STINGRAY	12 (30)	DOUBLE	5000 (19000)	20 (6)	45 (34)
DOLPHIN	12 (30)	DOUBLE	5000 (19000)	40 (12)	90 (67)
SHARK	16 (41)	DOUBLE	7000 (26500)	40 (12)	120 (89)
TARPON	16 (41)	DOUBLE	11000 (41600)	10 (3)	70 (52)
1000 RPM MODELS					
PERCH	4 (10)	DOUBLE	700 (2600)	70 (21)	30 (22)
PIKE	6 (15)	DOUBLE	1400 (5300)	70 (21)	50 (37)
CATFISH	8 (20)	DOUBLE	2500 (9500)	70 (21)	75 (56)
KINGFISH	10 (25)	DOUBLE	3600 (13600)	70 (21)	110 (81)
SAILFISH	12 (30)	DOUBLE	5000 (19000)	60 (18)	125 (93)
MARLIN	16 (41)	DOUBLE	7000 (26500)	50 (15)	140 (103)
WHALE	24 (61)	DOUBLE	15000 (57000)	20 (6)	180 (135)

Gator Pumps are steel fabricated with heavy duty structural steel tubing. Cases and impellers are made of 3/8" steel plate.

Gator Trailer Centrifugal Pumps supply large volumes of water using tractor, diesel, or electric power. Trailer pumps are available with either 540 or 1000 RPM PTO drive.

Operation includes backing the trailer in to the water, attaching flexible drive shaft between power unit and pump shaft and connecting industrial tubing to the discharge pipe with a clamp.

Trailer allows pump from several sites and water levels. Maintenance is practically eliminated by a design without seals or priming devices.

High flow per horsepower combined with solid steel fabrication make Gator the best trailer pump on the market.

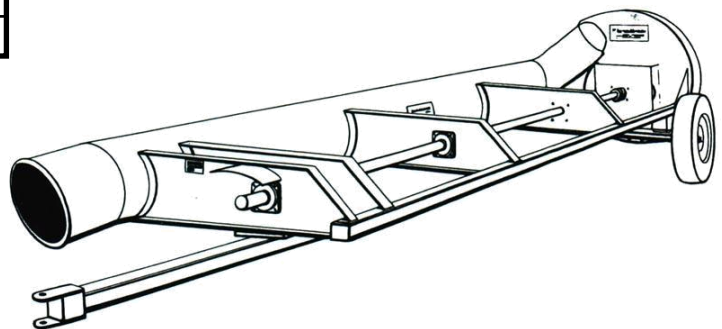

M&L Engine, LLC

1212 Saint Charles St. Houma, LA 70360

(985) 857-8000 ♦ (800) 960-0068

www.mlengine.com email: sales@mlengine.com