

FORD INDUSTRIAL NATURAL GAS OPEN POWER UNIT

Models: TSG-415 MSG-425 CSG-637 WSG-1068

52 HP to 230 HP

POWERED BY:

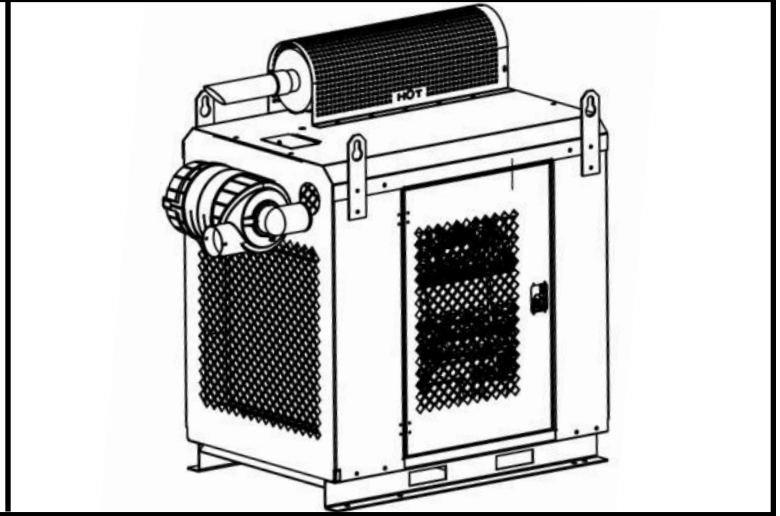
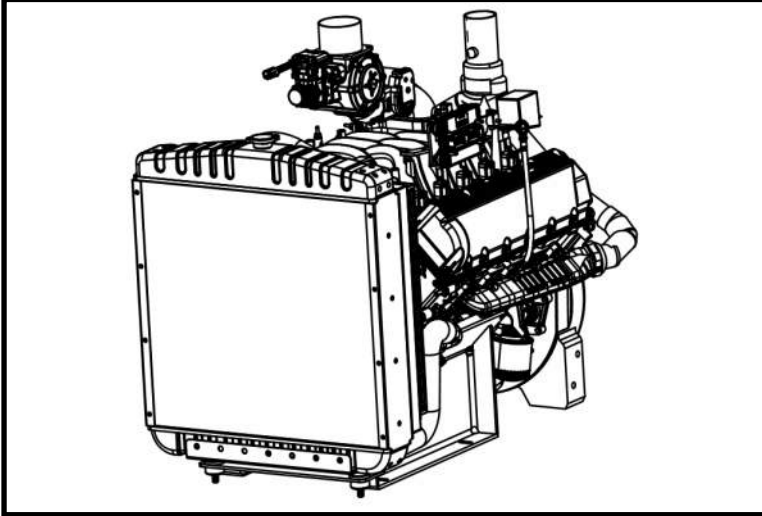

Power Unit Specifications

- Ford Natural Gas Variable Speed Engine
- EPA Certified
- Murphy Power View Control Panel with Key Switch
- Safety Shutdown System (Low Oil Pressure & High Coolant Temperature)
- Electronic Fuel System
- Radiator
- Fan Guard
- Industrial Exhaust Muffler / Catalyst
- Industrial Air Cleaner
- Front and Rear Engine Support Legs
- Steel Skid
- Throttle
- Oil and Fuel Filters
- 12 Volt Electrics
- Owner's Manual

ENGINE HORSE POWER @ RPM RATING		
Engine	Horse Power	RPM
TSG-415	26	1800
TSG-415	52	3600
MSG-425	47	1800
MSG-425	84	3200
CSG-637	63	1800
CSG-637	110	3200
WSG-1068	115	1800
WSG-1068	230	3200



M&L Engine, LLC

1212 Saint Charles St. Houma, LA 70360
(985) 857-8000 ♦ (800) 960-0068

www.mlengine.com email: sales@mlengine.com

Engine Specifications

Manufacturer Ford
 Cylinder Arrangement 4, 6 or 10 in-line 4 cycle
 Horse Power at Rated RPM (bhp) Variable
 Governor Type Electrical
 Frequency Regulation 3-5%
 Air Cleaner Replaceable Element

Optional Accessories

- Battery with Cables
- Battery Charger
- Bearing Supported Stub Shaft
- Hydraulic Pump Adapter
- Murphy Auto Start Panel
- Welded Steel Skid
- PTO with Kevlar Heavy Duty Plate
- Aluminum Enclosure with Stainless Steel Hardware
- Contact us for custom accessory options

Optional PTO Specifications

TSG-415

Manufacturer W.P.T.
 Model WTD-07-152
 Number of Drive Plates 1
 Diameter of Clutch Drive Plate 7.5
 SAE Size 5
 Warranty 1 year 2,000 hour

MSG-425

Manufacturer W.P.T.
 Model WTD-10-149
 Number of Drive Plates 1
 Diameter of Clutch Drive Plate 10
 SAE Size 4
 Warranty 1 year 2,000 hour

Standard Panel

Power View Panel

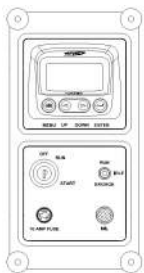

Optional Panel

Murphy Auto Start Panel



CSG-693 and WSG-1068

Manufacturer W.P.T.
 Model WTD-11-13F
 Number of Drive Plates 1
 Diameter of Clutch Drive Plate 11.5
 SAE Size 3
 Warranty 1 year 2,000 hour

Engine	EPA Certified	SAE Bellhousing to Flywheel Size	Weight lbs.	Dimensions in Inches					
				A	B	C	D	E	F
TSG-415	Certified	SAE 5 / 7.5"	TBA	TBA	TBA	TBA	TBA	TBA	TBA
MSG-425	Certified	SAE 4 / 10"	TBA	45.002	29.665	48.210	36.750	13.154	38.698
CSG-693	Certified	SAE 3 / 11"	TBA	56.470	31.875	54.350	42.520	13.836	44.080
WSG-1068	Certified	SAE 3 / 11"	TBA	59.937	34.085	60.490	48.290	14.518	49.461

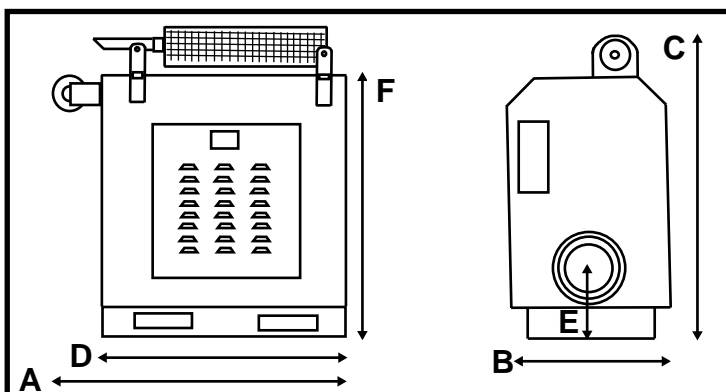

M&L Engine, LLC

1212 Saint Charles St. Houma, LA 70360
 (985) 857-8000 ♦ (800) 960-0068

www.mlengine.com email: sales@mlengine.com