

# ISUZU INDUSTRIAL DIESEL OPEN POWER UNIT

## 362HP @ 1950RPM

## Model number: 6UZ1XYBW

### POWERED BY:

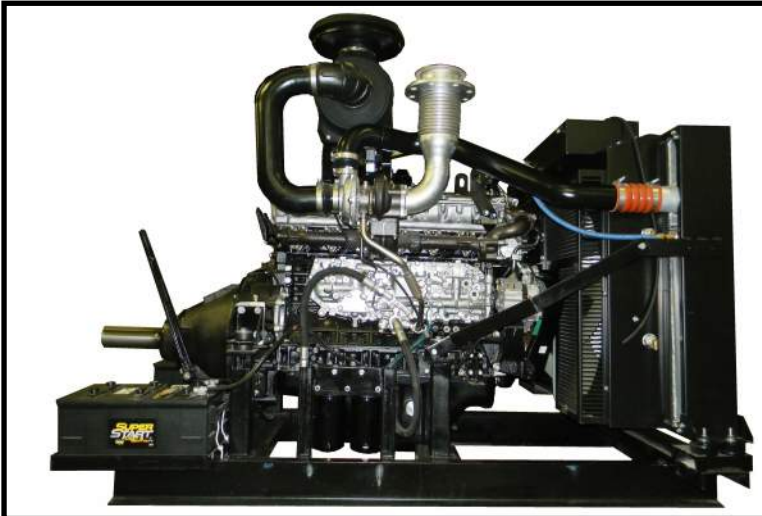

\* Pictures may include optional accessories.

### Power Unit Set Specifications

- Isuzu 6UZ1X Diesel 6 Cylinder 362 HP at 1950 RPM Turbo Charged, Charged Air Cooled Engine
- Isuzu Control Panel (Murphy Power View Display, Programmable Speed Setting, Throttle Control, and Key Switch)
- Safety Shutdown System (Low Oil Pressure & High Coolant Temperature)
- Common Rail Fuel System
- Radiator with Constant Torque Clamps
- Fan Guard
- Painted Bent Steel Plumbing
- Industrial Exhaust Muffler
- Industrial Air Cleaner
- Engine Support Legs
- Steel Skid
- Throttle
- Oil and Fuel Filters with 500 Hour Service Intervals
- 24 Volt Electrics
- Owner's Manual
- 5 Year 5,000 Hour Engine Warranty
- 1 Year 2,000 Hour PTO Warranty
- SAE 1 Bellhousing / SAE 14" Flywheel

### 6UZ1X Industrial Performance Curves:

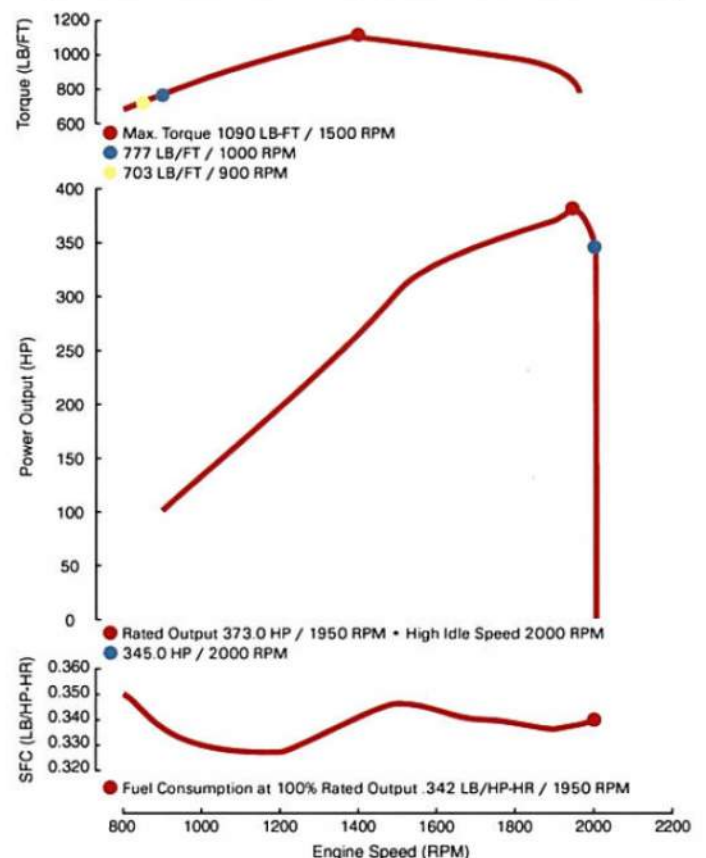

## Engine Specifications

Manufacturer	Isuzu
Engine Model	6UZ1X
Cylinder Arrangement	6 in-line 4 cycle
Rated RPM	1950
Horse Power at Rated RPM (bhp)	362
Governor Type	Electronic
Frequency Regulation	3-5%
Air Cleaner	Replaceable Element
<b>Lubrication System:</b>	
Oil Capacity w/out filter, qt.	38.04
Oil Filter Type	Spin-on
<b>Fuel System:</b>	
Fuel Shutoff Solenoid	Electric
Fuel Pump	Electric
Fuel Pump Priming	Electric
Fuel Line Supply	5/16
Fuel Line Return	5/16
<b>Cooling System:</b>	
Engine Coolant Capacity, qt	23.78
Radiator Coolant Capacity, qt	47.0
Fan Type	Puller (Pusher Available)
<b>Approx Fuel Consumption, (GPH):</b>	
100% Load	15.1
75% Load	11.3
50% Load	7.5

## Dimensions and Weights

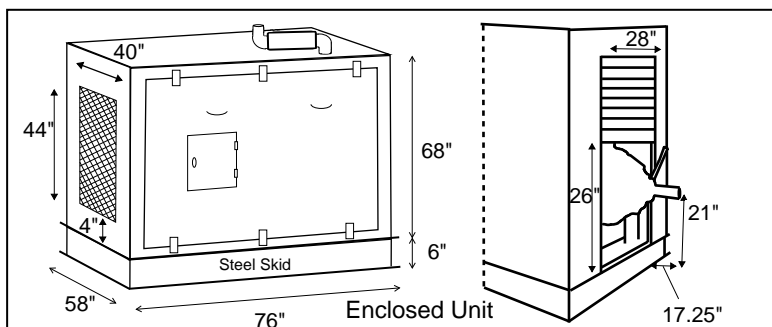
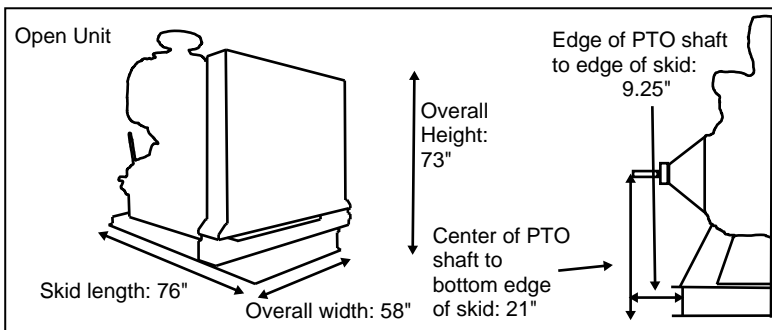

- Open Power Unit Weight : 3,600 lbs.
- Optional Enclosed Power Unit Weight : TBA lbs.

Standard  
Control  
Panel



Optional  
Remote  
Panel



Optional  
Murphy Auto  
Start Panel



## Optional PTO Specifications

Manufacturer	W.P.T.
Model	WTD-14-21H
Number of Drive Plates	2
Diameter of Clutch Drive Plate	14
SAE Size	1
Warranty	1 year 2,000 hour

## Optional Accessories

- PTO with Dual Plates
- Remote Panel Option with Wire Harness
  - Available in:
    - 6 foot
    - 10 foot
    - 20 foot
- Murphy Auto Start Panel Includes 10' Wire Harness with Optional Accessories:
  - 15 Watt Solar Panel
  - 24 Volt Battery Charged
  - Mechanical Float Switch
- (2) Racor Fuel / Water Separator
- (2) 8D Batteries - 24 Volt, Dual Batteries
- 24 Volt Battery Charger
- Battery Cables
- ESD Air Shut Down Valve
- 6' Manual Cable for ESD Valve
- Spark Arrestor
- Oil Drain Valve
- Hydraulic Pump Adapter
- Weatherized Aluminum Enclosure with Stainless Steel Hardware



**M&L Engine, LLC**

1212 Saint Charles St. Houma, LA 70360  
(985) 857-8000 ♦ (800) 960-0068

[www.mlengine.com](http://www.mlengine.com) email: sales@mlengine.com