

# UM6WG1TC-AA2

M2 Rating  
600 H.P. @ 2000 R.P.M.

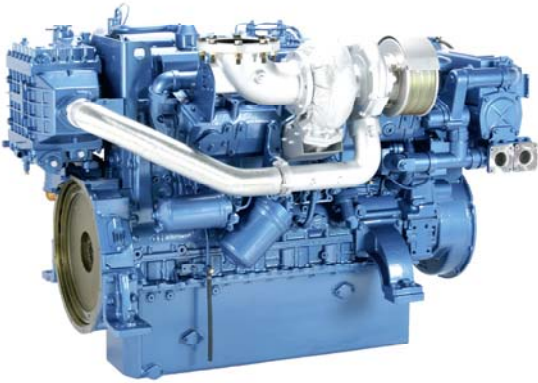

UM6WG1TC-AA2 PERFORMANCE CURVE

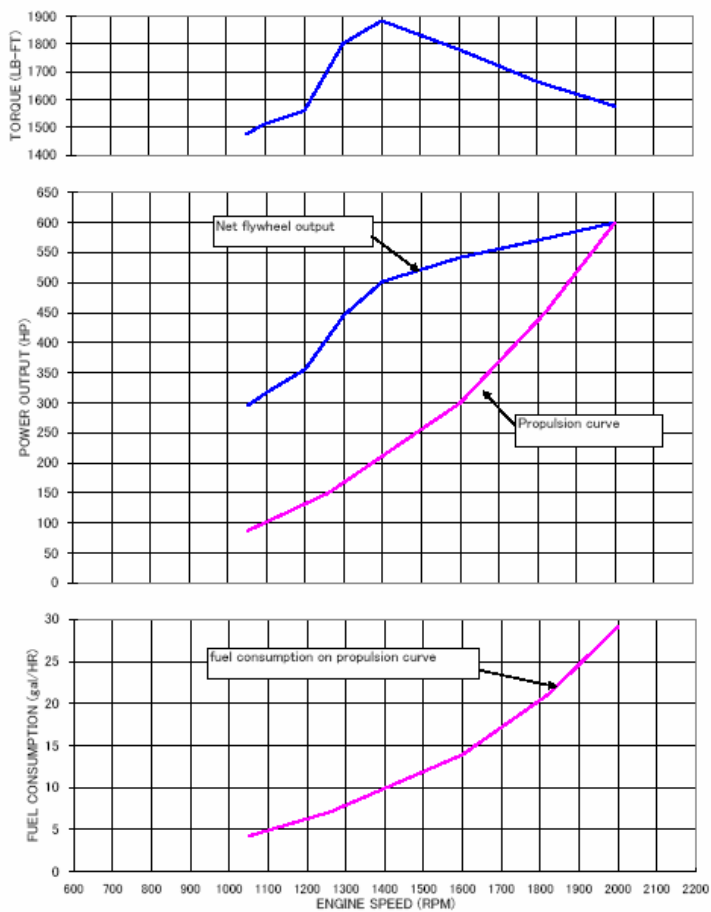

## Features:

- 15.7 Liter Displacement
- Bore & Stroke 5.79 x 6.06
- Torque: 1903 lbs./ft
- Choice of heat exchanger cooled or keel cooled
- SAE housing for easy transmission mounting
- Mechanical fuel system for ease of maintenance
- Oversized air cleaner
- Oil filters
- Water/fuel separator
- 24 Volt electrical system
- Oil sump pump
- Deep sump oil pan
- Cromard liners
- Glow plugs for cold start
- Zinc anode protection
- Several fluid service drains
- Complete instrument panel

**ISUZU**  
*Marine*

46401 Commerce Center Dr. • Plymouth, MI 48170 • Phone: 734-582-9400

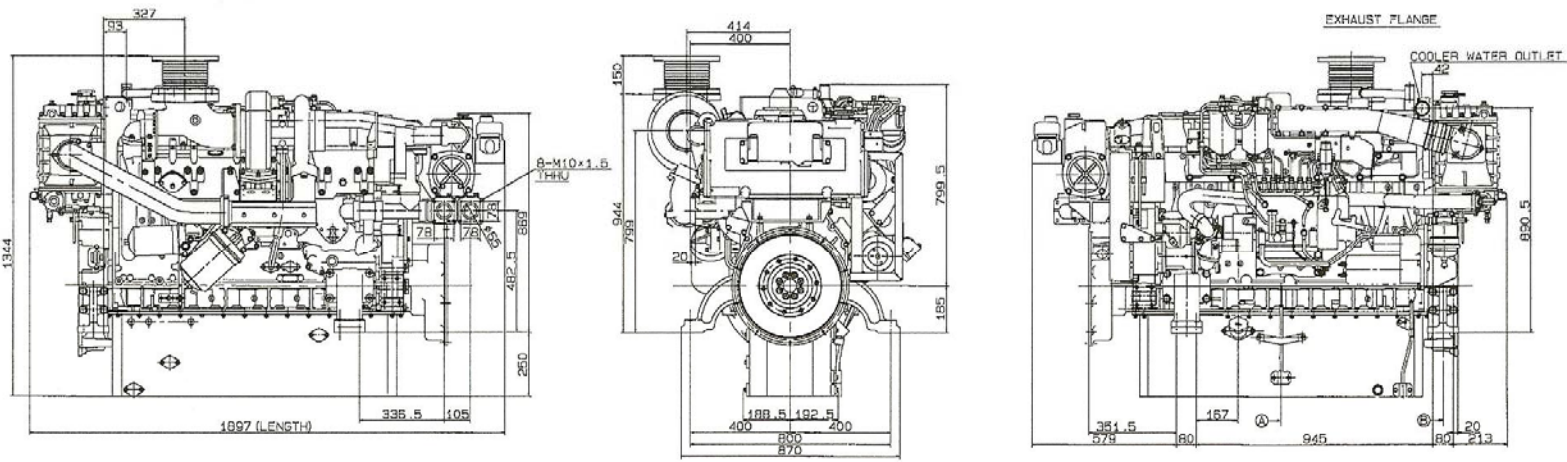

Weight Bobtail: Heat Exchanger 1470 Kg (3240lbs) Keel Cool 1460 Kg (3219)

### Standard Equipment

- 24V, 7.4 kw starter
- 24V, 50 amp Alternator
- SAE housing & Flywheel
- Left hand rotation (looking ay flywheel)
- Seawater Pump
- Dry Exhaust Elbow
- Oil Sump Pump



### Available options:

- Heat Exchanger or Keel Cooling
- Nikko Marine transmissions
- Front add-on pulley
- Vibration isolators
- Extended wire harness
- Dual Station Panel
- Keel coolers
- Service & Parts Manuals
- Front PTO (capacity 400H.P.)
- Bilge Pump

**ISUZU**  
*Marine*

46401 Commerce Center Dr. • Plymouth, MI

48170 • Phone: 734-582-9400

Distributed by:

